

# VPx

## PN16 Composite Valves

Model code	Ordering code
VPS16P	137319
VPS25P	137320

Model code	Ordering code
VPM16P	1373xx
VPM25P	1373xx

Model code	Ordering code
VPT16P	1373xx
VPT25P	1373xx

### MOUNTING INSTRUCTIONS

**1**

**2**

**3**

**mixing**

VPS

VPM

VPT

**diverting**

VPM

VPT

**VPx + MVP**

**VPx + A5**

**VPx + MPO**

The performances stated in this sheet can be modified without any prior notice.

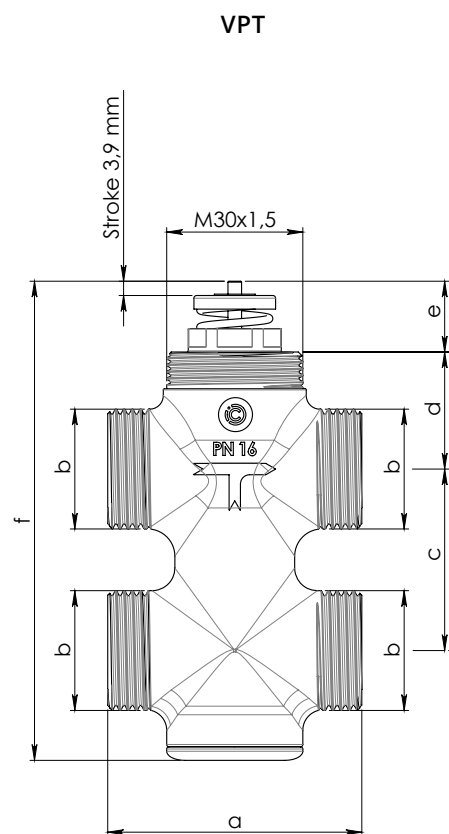
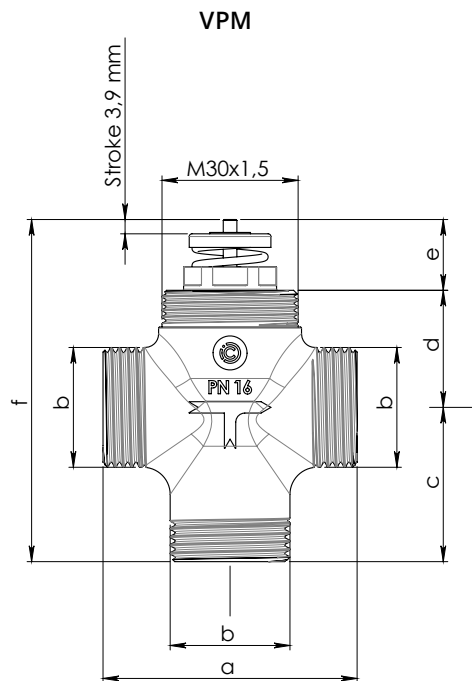
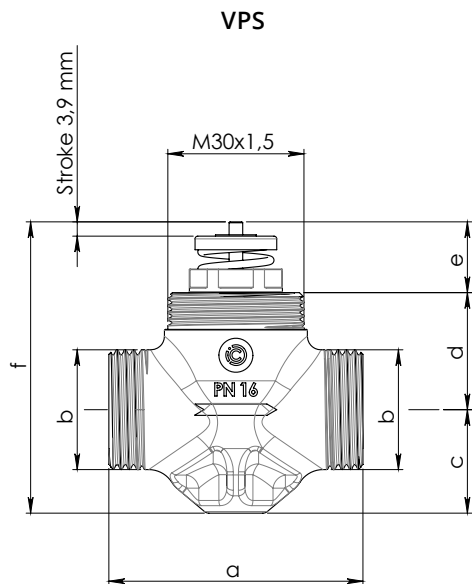

Model	a	b	c	d	e	f	Weight [g]
VPS16P	52	G1/2"	20	25,8	15,6	61,4	36
VPS25P	56	G 3/4"	22,8			64,2	42
VPM16P	52	G1/2"	25	25,8	15,6	66,4	38
VPM25P	56	G 3/4"	34			75,4	45
VPT16P	52	G1/2"	40	25,8	15,6	102,8	60
VPT25P	56	G 3/4"	40			105,6	67