

Globe Valves Actuators

MODEL CODE	ORDERING CODE	FORCE [N]	POWER SUPPLY	DESCRIPTION
MVE204	1373xx	400	230 V AC ±10%	Long yoke, modulating/ floating control
MVE206	1373xx	600		
MVE210	1373xx	1000		
MVE215	1373xx	1500		
MVE222	1373xx	2200		
MVE204S	1373xx	400	230 V AC ±10%	Short yoke, modulating/ floating control
MVE206S	1373xx	600		
MVE210S	1373xx	1000		
MVE215S	1373xx	1500		
MVE222S	1373xx	2200		



APPLICATION AND USE

MVE2xx is a flexible electro-mechanical actuator for the control of two and three way globe valves in:

- heating and cooling systems
- Air Handling Units
- district heating plants
- industrial temperature control systems.

MVE2xx can be controlled either by a proportional (modulating) signal or by an increase/decrease (Floating) signal.

It is easy to mount and connect the actuator.

The actuator has a fine resolution (500 steps on the full stroke range) for exacting fluid control and it is able to self-calibrate on a different stroke without the need of any user action (this function is DIP switch selectable on the field).

MVE2xx has intelligent behaviour and alarm functionality in case of unexpected operation, feedback of alarms to the user is provided by LEDs (GREEN and RED) on the control board.

N.B.: Do not use the actuator if not coupled with its relating valve.

TECHNICAL CHARACTERISTICS

DESCRIZIONE		MVE204 MVE204S	MVE206 MVE206S	MVE210 MVE210S	MVE215 MVE215S	MVE222 MVE222S
Supply voltage F N		230 V AC ±10%, 50-60 Hz				
Power consumption (running)		10 VA/4,5 W	13 VA/6 W	18 VA/8 W	21 VA/11 W	25 VA/10 W
Power consumption (holding)		8 VA/4 W	11 VA/5 W	11 VA/5 W	13 VA/7 W	10 VA/4 W
Running time	Modulating	15 s (for valves with stroke from 5 to 15 mm)				60 s (for valves with stroke from 5 to 60 mm)
		20 s (for valves with stroke from 15 to 25 mm)				
		30 s (for valves with stroke from 25 to 60 mm)				
	Increase/decrease	60 s				
Stroke		5-60 mm (limited to 30 mm for MVE.S)				
Force		400 N	600 N	1000 N	1500 N	2200 N
Duty cycle		max 50%/60 minutes				
Analogue input Y M		Voltage 0-10 V - impedance > 100 kΩ (range: 0-10 V DC, 2-10 V DC, 0-5/2-6 V DC, 5-10/6-10 V DC) 500 Ω (range 4-20 mA)				
Digital inputs Y1 Y2		Connection of Y1, Y2 to M				
Output V+		Voltage 16 V DC ± 0,5 V, max load 25 mA,				
Output U		Voltage 2-10 V DC (0-100%), max load 2 mA				

The performances stated in this sheet can be modified without any prior notice.

DESCRIZIONE	MVE204 MVE204S	MVE206 MVE206S	MVE210 MVE210S	MVE215 MVE215S	MVE222 MVE222S
Room temperature	Operation -10°C to 55°C; storage -20°C to 55°C				
Room humidity	Max. 90% R.H.				
Protection degree	IP54 (with PG13,5 cable gland - not supplied)				
Insulation class	⏚				
Standard	Emission/Immunity EMC 2014/30/UE according to EN 61326-1:2013 standard LVD 2014/35/UE according to EN61010-1 standard				
Material	Housing: aluminium - cover: ABS plastic				
Colour	Aluminium / white				
Weight [kg]	1.7 (MVE2xx); 1.6 (MVE2xxS)				

OPERATION

The actuator translates the control signal (modulating or 3 point floating) from the controller into a valve position. A modern brushless DC motor in the actuator drive a gear train and a worm gear – screw jack mechanism convert the motor revolutions into accurate and repeatable linear movements.

Control Signal

MVE2xx can be controlled by one of 2 main control types.

- 3 point floating;
- modulating (or proportional) signal with field selectable range (e.g., 0-10 V DC, 2-10 V DC, 0-5/2-6V DC, 5-10/6-10 V DC and 4-20 mA).

Manual Override

There is a manual operation handle on the actuator. When it is lowered (manual override ON), the power supply to the motor power stage circuitry is cut and the motor stops. The actuator can be operated manually and the valve positioned accordingly. The manual override lever latches in position until it is raised again, then board and motor will be powered again. At the end of this operation the actuator moves to initial position (on the basis of DIP n. 1 setting) then it follows the control signal. When the manual override is engaged the GREEN and the RED LED are ON.

Manual operation handle can also be used to modify any DIP switch setting or as re-set function after any alarm occurrence. The actuator is supplied with the manual override lowered (ON). It is not necessary to remove power supply to modify DIP switch setting, but, in this case, take care of 230Vac voltage.

Feedback Position

The actuator utilizes a 2-10 V position feedback (look at DIP n. 1 setting).

Calibration

The actuator has both auto and manual stroke calibration, DIP n. 7.

In factory delivery the auto stroke calibration is enabled – manual calibration is not necessary unless maintenance is required on the valve or certain alarm functions are desired.

End Point Auxiliary Switches (accessory DMVE)

End point switches change over when the valve is fully open or closed. They are free contact with 24V AC/DC, 4A max voltage to terminals.

End point switches can be utilized to indicate valve stroke end positions and for relay control of additional plant equipment. When the actuators are controlled individually or in sequence, it is possible to use the end switches to toggle when the valve is fully open or fully closed. The auxiliary switch position according to control signal (Y) is shown in the table below.

CONTROL SIGNAL (Y)	RELAY KC1	RELAY KC2
0-0,5 V DC	KC1 to K2	KC2 to K3
0,5-9,5 V DC	KC1 to K1	KC2 to K3
9,5-10 V DC	KC1 to K1	KC2 to K4

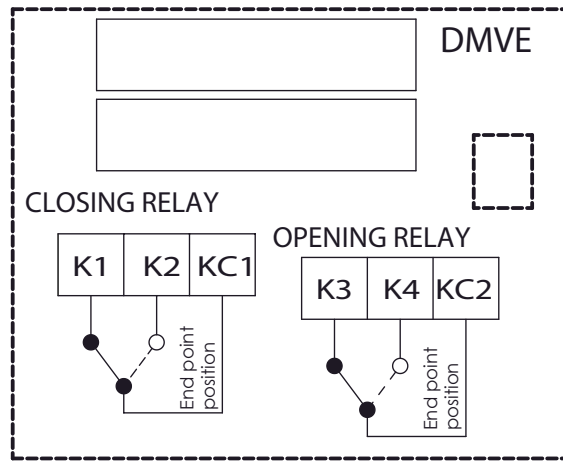

Diagnostic

The actuator is provided with a self diagnostic algorithm able to detect faulty conditions:

- stroke calibration out of range 5-60mm;
- unexpected stall condition (e.g. valve stuck or extra stroke due to actuator link loose);
- voltage supply out of range.

These faulty conditions are signalled via the GREEN and RED LED on the electronic board blinking accordingly (see Diagnostic – Alarm Function Table).

ASSEMBLING

The actuator can be mounted with any orientation but never up-side down. When the fluid temperature exceed 120°C the actuator shall be mounted leaning 45°.

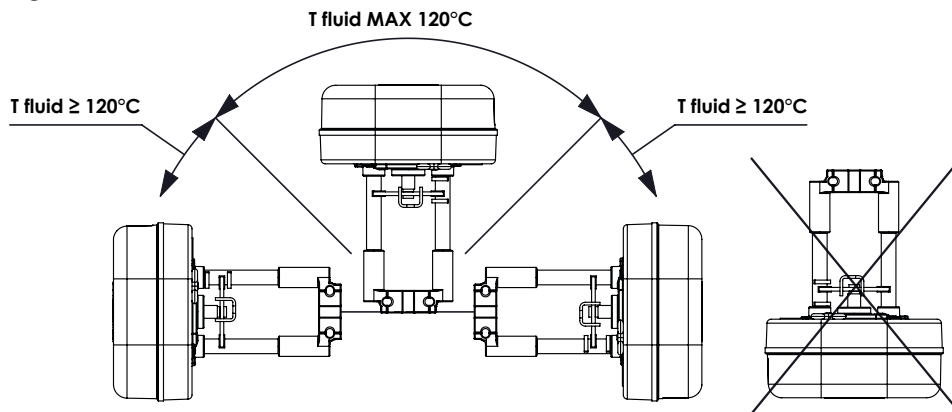

To mount the actuator on to a valve, position the valve stem to the bottom of its travel, slide the actuator onto the valve neck, adjusting with the manual override the screw jack position so the square nut on the valve spindle fits into the groove on the cross bar. Then slide the brace into the groove on the valve neck and secure the nuts.

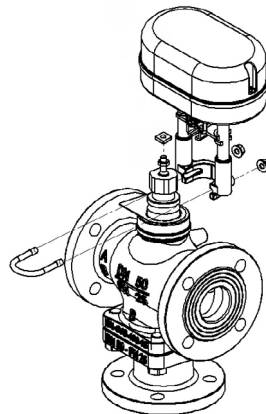

See mounting instructions for full details.

MAINTENANCE

The actuator is maintenance free.

ACCESSORIES

DMVE	End point auxiliary switches
GMVE	Thermal insulation for MVE actuators *
GMVES	Thermal insulation for MVE.S actuators *
KIT-P13.5	10 cable glands kit (nuts and gaskets included)
KIT-T13.5	Kit 10 caps for cable glands hole (nuts and gaskets included)
248	Stem heater 24 V, 50 W (suggested when the fluid temperature is below 0°C) *

* It is not possible to install both thermal insulation (Gxxxx) and stem heaters.

ELECTRICAL CONNECTIONS

Remove the cover screw with a screwdriver and then remove the cover as shown in the picture beside.

MVE is equipped with a 6 poles removable 2 poles terminal (F and N) for main control; the each pole of the plug is clearly marked and the same label are reported on the electronic board. Before powering up the actuator make sure the plug is properly connected to the electronic board and the label on the plugs and on the board match.

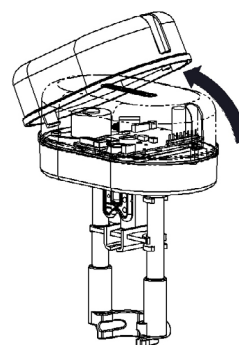

Use cable gland PG13,5 model (not supplied).

TERMINAL BLOCK

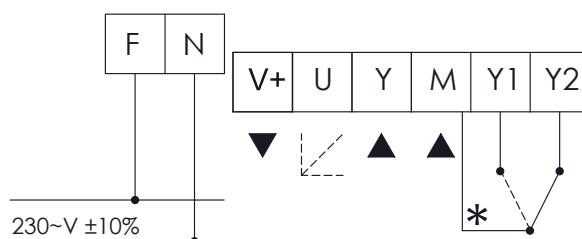

* Floating only sink (connect Y1, Y2 to M)

(*) In order to use the floating control the only possible connection is * Floating only sink (connect Y1, Y2 to M) between terminal M and Y1/ Y2. Do not connect Y1/Y2 to phase (F) or neutral (N).

LABEL	DESCRIPTION	FUNCTION	WIRE SIZE	MAX. WIRE LENGTH
F	230 V AC	Power Supply	AWG16 (min 1mm ² - max 1.5mm ²)	75 m
N				
Y	0..10 V DC	Modulating Control Input	AWG20 (min 0.5mm ² - max 1.5mm ²)	200 m
M	0 V (Common)			
Y1	Open	Floating Control Input	AWG20 (min 0.5mm ² - max 1.5mm ²)	200 m
Y2	Close			
V+	16 V DC	Voltage Output (max 25 mA)	AWG20 (min 0.5mm ² - max 1.5mm ²)	200 m
M	0 V (Common)			
U	2±10 V DC	Feedback Output Signal	AWG20 (min 0.5mm ² - max 1.5mm ²)	200 m
M	0 V (Common)			

Note: To avoid damages to electronic components caused by the PCB bending, do not press too much while fixing the terminal block.

GROUND CONNECTIONS

Connect the ground terminal to the proper screw labelled with the ground symbol as shown in the picture here below.

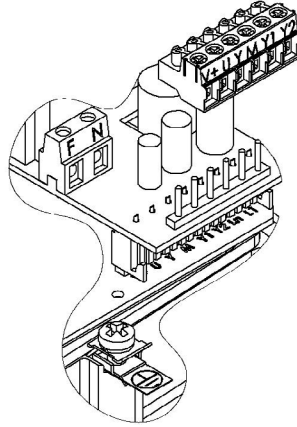

SAFETY PRESCRIPTIONS

230 V products

- Install on the power supply line a protecting device to avoid short circuits (fuse or magneto-thermic) according to the specifications in force;
- in case of accidental removal of the cover to make sure that power is disconnected before working on the actuator or near it;
- the products are maintenance free.

WIRING DIAGRAMS

3 point floating control

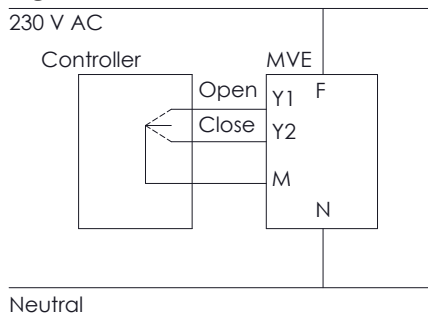

Modulating control (0-10 V DC)

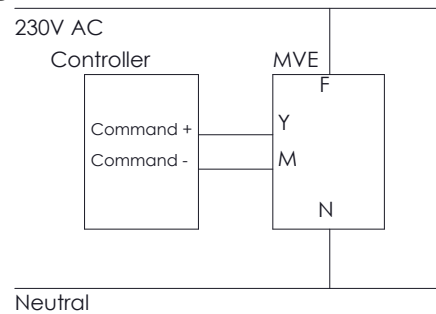

DIP SWITCHES SETTINGS

Set the DIP switches according to tables below. Power down and power up again the actuator or act on the manual override handle to be sure that settings will be recognized.

Factory settings

DIR		REV
MOD		INC
---		SEQ
0 - 10		2 - 10
0 - 5, 2 - 6		5 - 10, 6 - 10
---		4 - 20 mA
AUTO		MAN

OFF ON

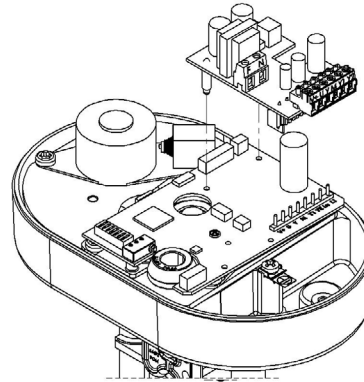

DIP SWITCH	OFF	ON
1	<p>Direct Action</p> <p>U= feedback U = 2V U = 10V</p>	<p>Reverse Action</p> <p>U= feedback U = 10V U = 2V</p>
2	<p>Modulating Control (MOD) (Input between Y [+] and M [-])</p>	<p>3 point floating (INC) (Y1 open-extend , Y2 close-retract connected to M)</p>
		<p> </p>
3	-	Selection of sequence mode, control range defined by DIP n. 5
4	Modulating Control 0-10 V DC (DIP n. 2 OFF only)	Modulating Control 2-10 V DC (DIP n. 2 OFF only)
5	Sequence Control 0-5 V DC with DIP n. 4 OFF only Sequence Control 2-6 V DC with DIP n. 4 ON only (DIP n. 3 ON only)	Sequence Control 5-10 V DC with DIP n. 4 OFF only Sequence Control 6-10 V DC with DIP n. 4 ON only (DIP n. 3 ON only)
6	Voltage Input Signal V DC (input between Y [+] and M [-])	Current Input Signal 4-20 mA (input between Y [+] and M [-]). In this case DIP n. 4 must be set to ON.
7	Automatic Calibration: the actuator updates the stroke range if an unexpected mechanical stop is detected for at least 10 s	Manual Calibration: the actuator calibration is started moving the DIP from OFF to ON or vice versa. With DIP in ON in case of extra stroke or if an unexpected endpoint is detected, the actuator will never update the stroke

DIAGNOSTIC - ALARM FUNCTIONS

N°	LEDS BEHAVIOUR	ERROR	ACTUATOR USE	ACTUATOR BEHAVIOUR		TYPICAL TROUBLE SHOOTING CONDITION	RESET PROCEDURE
				AUTOMATIC CALIBRATION (DIP N. 7 OFF)	MANUAL CALIBRATION (DIP N. 7 ON)		
1	RED ON	Valve stroke less than 5mm	Calibration/ first installation	The actuator pushes/pulls 2 times (unexpected stall) trying to remove the possible obstacle. After 2 tries an alarm is signalled and the actuator moves to initial position and does not respond to control signal. Stroke value is not updated because out of range	The actuator pushes/pulls 2 times against endpoint during calibration and the actuator moves to the initial position and then it does not respond to the control signal. The actuator keeps the previous stroke	Valve with a stroke length lower than 5mm	Remove power and power up again
2	RED LED quick blinking + GREEN ON	Stroke longer than 60mm	Calibration/ first installation	The actuator exits the 60mm stroke range and it moves toward the new stroke limit signalling an anomaly. The actuator pushes/pulls 2 times against the new stroke limit, then it goes back to the initial position still signalling the anomaly until it is not within 60mm. The actuator does not calibrate the stroke after 10s (wrong range)	The actuator exits the 60mm stroke range and it moves toward the new stroke limit signalling an anomaly. The actuator pushes/pulls 2 times against the new stroke limit, then it goes back to the initial position still signalling the anomaly until it is not within 60mm. The actuator does not calibrate the stroke after 10s (wrong range)	Valve with a stroke length longer than 60mm	Remove power and power up again
3	RED Quick Blinking	Unexpected stall within the calibrated stroke range	normal operation	The actuator tries 5 times against the new stall condition and then after 10s the actuator updates the new stroke length	The actuator tries 5 times against the new stall condition. At the end of the attempts the fault will be signalled. The actuator does not update the new stroke length, but after 60s makes other attempts to verify the stall condition	Valve stuck	Inverted control signal
4	RED Quick Blinking	Stroke longer than expected	Normal operation	The actuator moves toward the new stall condition with a lower speed; after 10s the actuator updates the new stroke value	The actuator moves toward the new stall condition with a lower speed; after 10s the actuator does not update the new stroke value	Stem connection loose or valve damaged	Inverted control signal
5	RED slow Blinking	Low Power Voltage	Normal operation	The actuator is still working but performance cannot be guaranteed	The actuator is still working but performance cannot be guaranteed	1. Wrong transformer size 2. Unstable power	Correct Voltage Power
6	RED slow Blinking	High Power Voltage	Normal operation	The actuator is still working but performance cannot be guaranteed	The actuator is still working but performance cannot be guaranteed	1. Wrong transformer size 2. Unstable power	Correct Voltage Power

STANDARD LEDs

N°	LED	ACTUATOR STATUS
1	GREEN ON	The actuator arrived at the extreme point of the stroke read
2	GREEN BLINKING	The actuator arrived at the intermediate point of the stroke read
3	RED GREEN BLINKING	The actuator is reading the stroke or it is going to initial position
4	RED GREEN ON	Manual control ON, the actuators ignores the control signal. ATTENTION! The electronic board is electrically supplied

DIMENSIONS [mm]

MVE

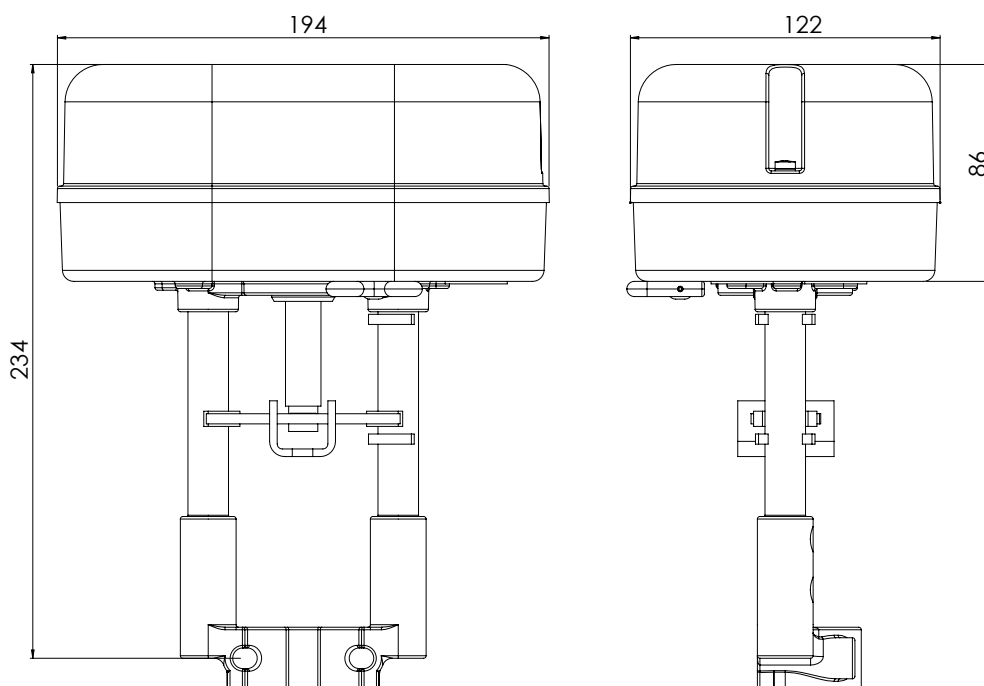

MVE.S

